

StowAway²

Cargo Carriers

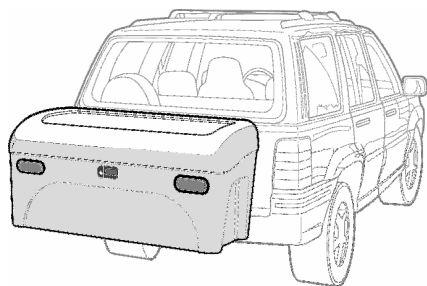

Basic Models 021.1, 031.1
Standard Sport Models 022.0, 032.0
MAX Sport Model 024.0
Spare Tire Model 022.1
Towing Model 022.2

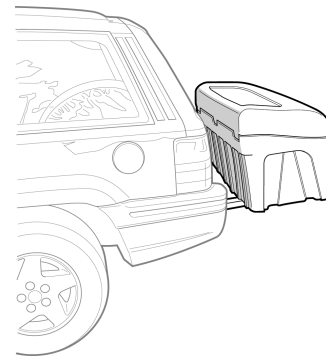

Assembly Instructions

REV. 0510

Please review the instructions and warranty carefully before assembling the unit

Assembly of the StowAway is best accomplished with two people. Assembly and installation are the end user's responsibility and beyond PRP's control. PRP limits its warranty to the repair or replacement of a defective product for up to five years from retail purchase. Damage to your vehicle, cargo, or to any person or property is excluded.

Each StowAway cargo box is assembled and tested at our factory to ensure proper fit and function.

Safety Guidelines when using the Stowaway

- **EXHAUST WARNING**– Do not install the StowAway on a vehicle equipped with an exhaust system that directs the engine exhaust toward the cargo box, as damages to the box and its contents may occur. The tailpipe must direct the exhaust **away** from the cargo box, either downward or to the side. Exhaust tips that will direct the exhaust down or to the side are commonly available at automotive accessories stores and websites. Alternatively we offer an exhaust shield PN #020.85 that will deflect exhaust away from the StowAway Carrier. Do not install the unit on a vehicle equipped with an aftermarket exhaust system unless the exhaust tip directs the exhaust away from the cargo box. In all instances the distance between the end of the exhaust pipe and the box should be a minimum of 14 inches.
- Do not exceed the rated tongue weight of the receiver hitch or of your vehicle. Do not exceed the gross vehicle weight at any time. **The carrier is not intended for off-road use.**
- Use with Class III 2" receiver hitches only (except LT model, which must use a Class II 1-1/4" receiver hitch). Maximum cargo capacity of the StowAway2 is 200 lbs. (except LT model, which has a maximum cargo capacity of 125 lbs.)
- For safety of your vehicle and cargo carrier, obey posted speed limits and traffic cautions. Adapt your speed to the conditions of the road, the load being carried, and the overall vehicle length with the carrier installed.
- Do not use the StowAway for transporting people, animals, or flammables.
- Do not step on frame, or use the lid as a work or storage surface.
- Always keep lid locked when not in use or when storing. Please do not allow people to climb, get into or sit on the StowAway at any time.

Before driving with the StowAway please:

- Make sure all knobs, bolts, screws, and locks are firmly attached, tightened and locked before every trip. Knobs, bolts, screws, and locks must be periodically inspected for signs of wear, corrosion, and fatigue.



StowAway²

Cargo Carriers

To Assemble the StowAway Cargo Carrier

Remove parts from cartons and confirm that all parts have been received. Save all packaging until the unit is fully assembled and functional. Contact us at (800) 943-5377 if any parts are not received.

Box

- ① 1 ea—StowAway Base (Standard or Max)
- ② 1 ea—StowAway Lid (Standard or Max)

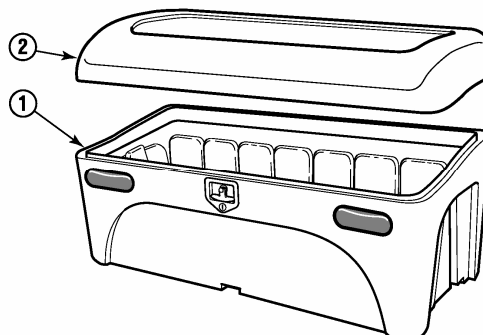

Frame (Specific to the model you purchased)

- ③ 1 ea— Sport Frame
- ④ 1 ea— Spare Tire Frame
- ⑤ 1 ea— Towing Frame
- ⑥ 1 ea— Basic Frame (not pictured)
- Max Only—2 ea Crossmember Overlays (not pictured)

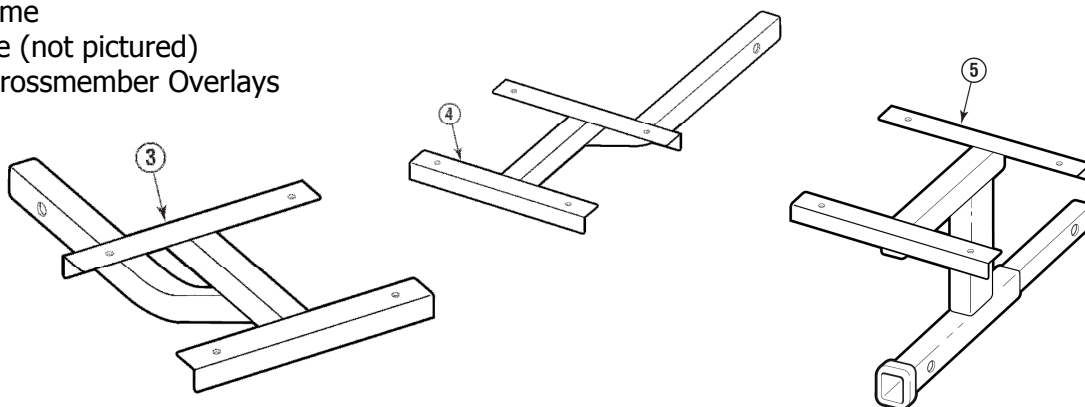

Hardware Kit

- ⑦ 1 ea— Drain Plug
- ⑧ 3 ea— Hinge Pins
- ⑨ 4 ea— 3/8" Bolts
- ⑩ 4 ea— Oblong Washers
- ⑪ 4 ea— 3/8" Lock Nut
- ⑫ 2 ea— Releasable Cable Ties (Wired models only)
- ⑬ 1 ea— Hitch Pin (not pictured)
- ⑭ 1 ea— Hitch Coupling Tightener P/N 020.6 (not pictured) (not included with the 021.1 Basic Model)

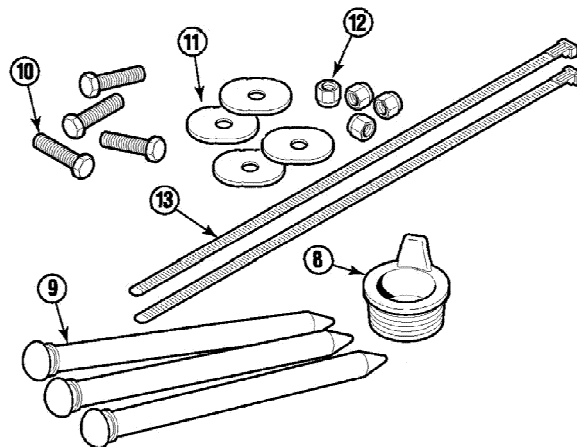

Tools Required for Assembly

Two adjustable end wrenches or socket wrenches with equivalent sockets



StowAway2

Cargo Carriers

1. Start Assembly

- Place hitch bar into vehicle's receiver hitch, aligning hitch pin holes. Install the hitch pin with keeper and, if included, the hitch coupling tightener.
- **Max Only**—Place the one of the crossmember overlays on each of the frame crossmembers. Align the holes between the two mating parts on each side.

2. Attach Box to Frame

- Place the box on the frame and align the box holes with those in the frame. Place an oblong washer over each hole and insert a bolt through the box and frame. **See Fig 1.** Tighten the lock nuts onto each bolt so that they are firmly in place (it is easiest to use a socket set on this step).

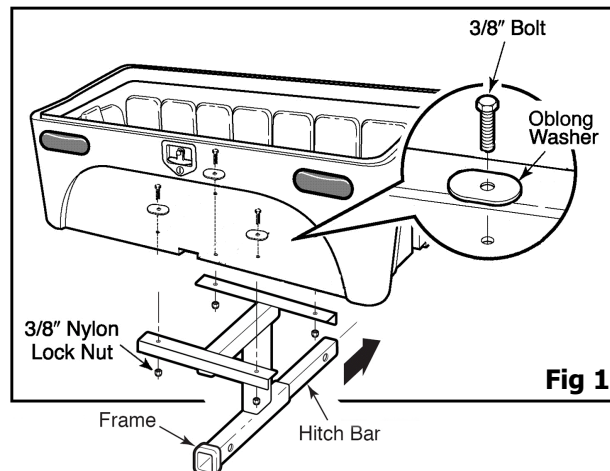

3. Attach Lid to Base of Box

- Locate the nylon hinge pins.
- Position the lid on the base of the box to line up the hinge holes **with the lid in the open position.**
- Reach under the inner lip at the back of the box and push the left hinge pin into position. The pin should be pushed all the way to the hinge pin collar. Repeat this process with the right hinge pin, followed by the center pin. It will be necessary to reach under the wire harness when installing the right hinge pin. A small tool may be used to tap the pins in place if necessary.
- Locate and remove the keys from the right latch rod.
- Close and latch the lid by turning the latch handle to ensure proper operation of the latching mechanism. The latch may be tight until the gasket has broken-in (usually within 24 hours if the lid is kept latched). Always store the carrier in the latched position. Using light downward pressure to compress the new gaskets for 24 hours before use will ensure proper latching operation and a tight weather seal.

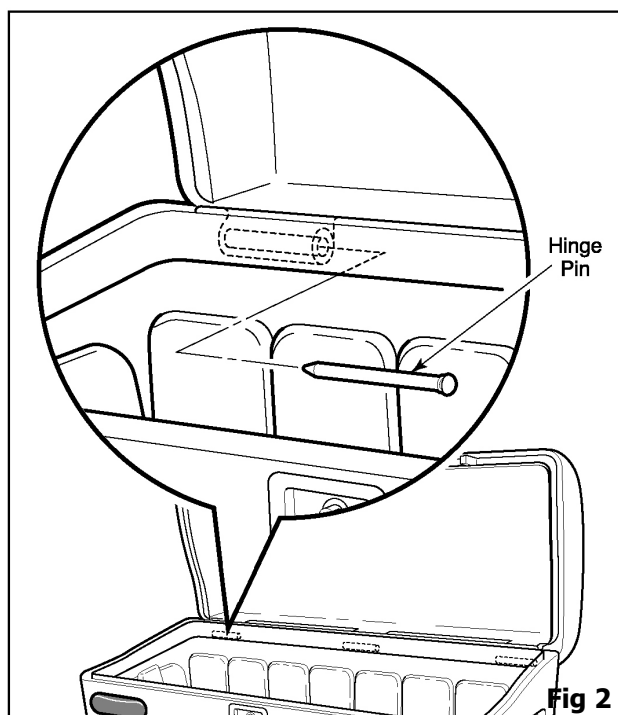

4. Final Assembly

- Push the drain plug into the drain hole at the bottom of the cargo box.
- **For wired models only**, pull the wire harness through the back of the box. Use the enclosed cable ties to secure the wiring harness to the **StowAway** frame. Adjust the cable ties as needed to protect the wiring harness.
- Plug the wire harness into your vehicle's wire harness plug. An adapter may be required for your particular vehicle. Consult your dealer or auto parts supplier. Adapters are also available at www.stowaway2.com or by calling us at 1-800-943-5377.
- Check lights to ensure that they are working properly.

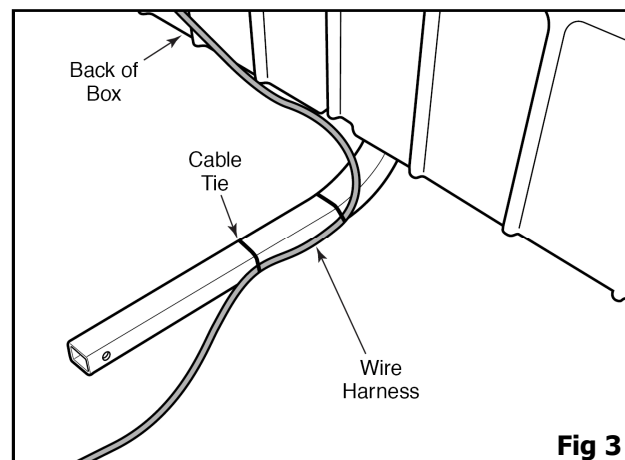

StowAway2

Cargo Carriers

5. Using the StowAway

Always use a hitch pin with keeper or hitch lock when driving with the StowAway Carrier.

The StowAway may obstruct the rear view of your vehicle's license plate. We encourage all owners to check license plate requirements in the states in which they will travel. A lit license plate bracket is included with most models (or is available as an optional accessory) for mounting your license plate to the back of the cargo box. The P/N for the license plate bracket is 020.7 for wired StowAways and P/N 020.75 for the Basic Model.

Always follow the safety guidelines listed on page 1 of these instructions.

Take care when touching the the StowAway lid in direct sunlight, as it can get warm. Do not load items directly on the lid if a lid rack is not installed.

The StowAway models are designed with water seals to prevent water from penetrating the interior of the box. While the gasket will work effectively under most conditions, water may penetrate the seal under severe conditions. Condensation may accumulate in the box under certain humidity conditions and water may drip onto box contents when opening the lid under wet conditions. *Items sensitive to dust or moisture contamination should be packaged accordingly for transport in the StowAway.*

The StowAway is equipped with a drain plug for ease of cleaning. Interior and exterior cleaning can be done with soap, water and a wash mitt. Trim Shine is recommended to brighten up the plastic surface after cleaning.

The StowAway is equipped with a locking latch and security features. However, a determined thief may access the box's contents by compromising these components. *Care should be taken when storing and transporting valuables in the StowAway Carrier.*

The lights are designed to provide taillight, brake light, and turn signal functionality. The lights on every cargo box are tested at the factory before shipping. If the lights do not function properly please try the following steps:

- Test the unit on another vehicle.
- Check the wire connector plugs at each taillight and at the vehicle plug. All should be tight and free from corrosion to each of the lights
- Consult your vehicle owner's manual to ensure that the terminals on the vehicle plug match the functions of those of the StowAway2 (see figure below).

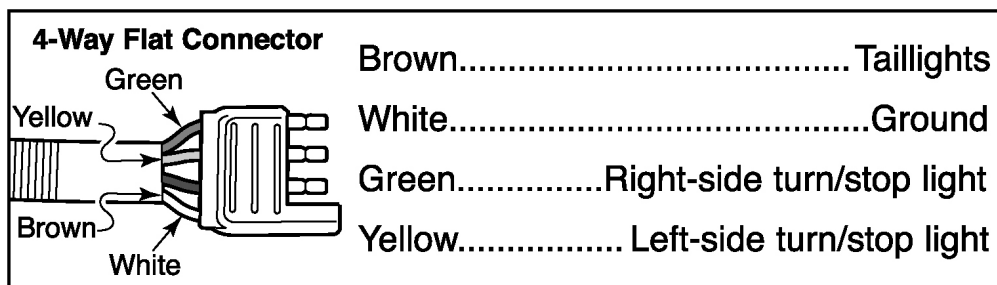

StowAway2 **Cargo Carriers**

Warranty on all StowAway Cargo Carriers

Pacific Recreational Products, Inc. warrants to the original retail purchaser of this StowAway cargo carrier that it is and shall remain free of defects in materials and workmanship for a period of five years from the date of retail purchase.

Should the purchaser discover a defect and notify PRP during the warranty period, PRP will, at its option, repair or replace the unit at no additional charge, or refund all or part of the customer's original purchase price. The limited warranty does not cover damage caused by collision, disaster, abuse, modification, misuse, normal wear or corrosion. Misuse includes but is not limited to overloading, improper installation and use with any hitch receiver of an incorrect size or style.

Limited warranty service may be obtained by first calling or writing to PRP and describing the problem or perceived defect. PRP may request documentation to fully understand the nature of the problem or defect. If a defect or problem is confirmed, PRP will, at its sole discretion, replace, repair, or authorize the return of the cargo carrier to PRP for a full or partial refund. Returns must be made to the specified address, along with proof of purchase date, using the original shipping container or equivalent. Unless otherwise authorized, return transportation charges must be prepaid by the purchaser.

All express and implied warranties for this product, including the warranties of merchantability and fitness for a particular purpose, are limited in duration to a period of five years from the date of purchase and no warranties, whether expressed or implied, will apply after this period.

If this product is defective, your sole remedy shall be repair replacement, or refund as provided above. In no event will IPI or any of its officers, employees, or agents be liable to you for any damages, including incidental or consequential damages arising out of the use of or inability to use the cargo carrier, even if PRP has been advised of the possibility of such damages, or for any claim by another party.

Our website www.stowaway2.com provides a list of commonly asked questions for reference. Please contact us if you would like a copy of these for reference.

Pacific Recreational Products, Inc.

7291 SW Tech Center Drive
Tigard, OR 97223

Phone: 1-800-943-5377
Fax: (503) 968-1433

www.stowaway2.com
e-mail: info@stowaway2.com

Thank you for purchasing a StowAway Cargo Carrier!

